

System No. W-L-2598

October 23, 2014

F Ratings — 1 and 2 Hr (See Item 1)

T Ratings — 1 and 1-1/2 Hr (See Item 1)

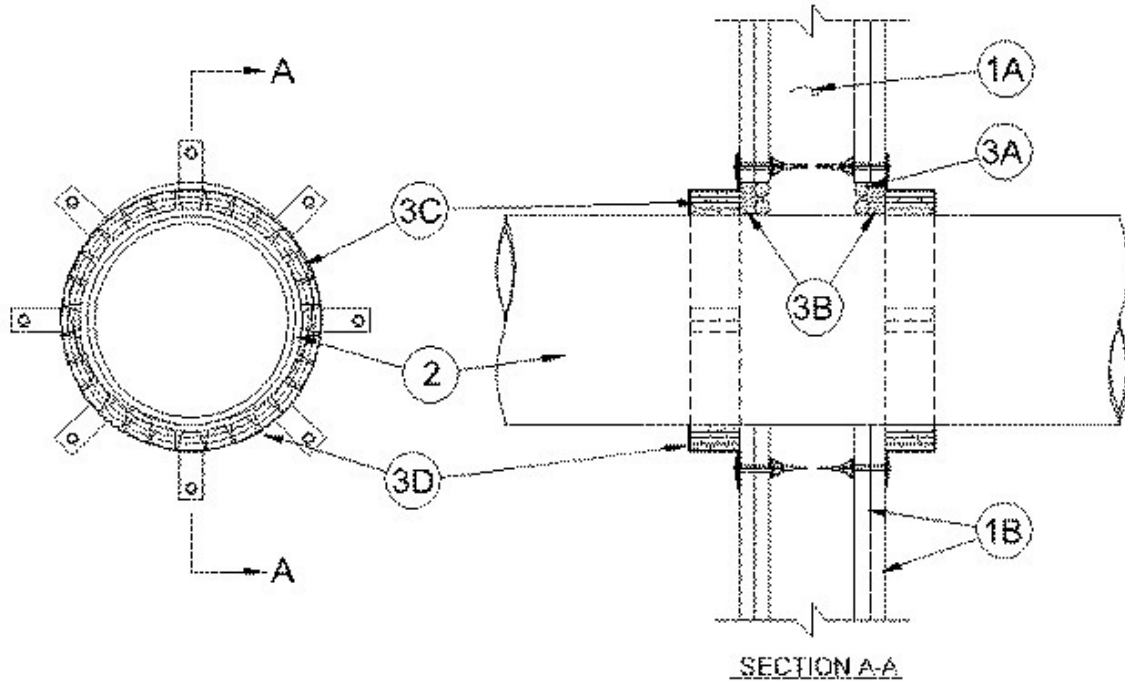

1. Wall Assembly — The 1 or 2 hr fire-rated gypsum board/stud wall assembly shall be constructed of the materials and in the manner specified in the individual U300, U400 or V400 Series Wall and Partition Designs in the UL Fire Resistance Directory and shall include the following construction features:

A. Studs — Wall framing shall consist of either wood or steel channel studs. Wood studs to consist of nom 2 by 4 in. (51 by 102 mm) lumber spaced 16 in. (406 mm) OC. Steel studs to be min 3-1/2 in. (89 mm) wide and spaced max 24 in. (610 mm) OC.

B. Gypsum Board* — Min 5/8 in. (16 mm) thick, 4 ft (1.22 m) wide with square or tapered edges. The gypsum board type, thickness, number of layers and orientation shall be as specified in the individual Wall and Partition Design. Max diam of opening is 5 in. (127 mm).

The hourly F Rating of the firestop system is equal to the hourly fire rating of the wall assembly in which it is installed. The hourly T Rating of the firestop system is 1 and 1-1/2 hr when installed in 1 and 2 hr rated walls, respectively.

2. Through Penetrant — One nonmetallic pipe to be installed either eccentrically or concentrically within the firestop system. The annular space shall be min 0 in. (point contact) to max 1/2 in. (13 mm). Pipe to be rigidly supported on both sides of wall assembly. The following types and sizes of nonmetallic pipes may be used:

A. **Polyvinyl Chloride (PVC) Pipe** — Nom 4 in. (102 mm) diam (or smaller) Schedule 40 cellular or solid core PVC pipe for use in closed (process or supply) or vented (drain, waste or vent) piping systems.

B. **Chlorinated Polyvinyl Chloride (CPVC) Pipe** — Nom 4 in. (102 mm) diam (or smaller) SDR 13.5 or Schedule 40 CPVC pipe for use in closed (process or supply) piping systems. Schedule 40 CPVC pipe for use in vented (drain, waste or vent) piping systems.

C. **Acrylonitrile Butadiene Styrene (ABS) Pipe** — Nom 4 in. (102 mm) diam (or smaller) Schedule 40 cellular or solid core ABS pipe for use in closed (process or supply) or vented (drain, waste or vent) piping systems.

3. **Firestop System** — The firestop system shall consist of the following:

A. **Packing Material** — In 2 hr rated wall assemblies, foam backer rod firmly packed into opening as a permanent form. Packing material to be recessed from both surfaces of wall as required to accommodate the required thickness of fill material.

B. **Fill, Void or Cavity Material* - Caulk** — Min 1/4 in. (6 mm) thickness of fill material applied within the annulus, flush with both surfaces of wall.

EVERKEM DIVERSIFIED PRODUCTS INC — Firestop 814+

C. **Fill, Void or Cavity Material* - Wrap Strip** — Nom 1/4 in. (6 mm) thick by 1 in. (25 mm) wide intumescent wrap strip. When diameter of penetrant is 4 in. (102 mm), two layers of wrap strip are individually wrapped around the through-penetrant with ends butted and held in place with masking tape. Butted ends in successive layer shall be offset. When diameter of penetrant is equal to or less than 3 in. (76 mm), one layer of wrap strip is wrapped around the through-penetrant with ends butted and held in place with masking tape. Wrap strips butted tightly against both surface of wall.

EVERKEM DIVERSIFIED PRODUCTS INC — Flame Tech Wrap Strip

D. **Steel Collar** — Collar fabricated from coils of precut min 0.016 in. (0.41 mm) thick (No. 28 gauge) galv steel available from fill material manufacturer. Collar shall be nom 1 in. (25 mm) deep with 1 in. (25 mm) wide by 1-1/2 in. (38 mm) long anchor tabs on 4 in. (102 mm) centers for securement to surfaces of wall. In addition, collar contains retainer tabs, 1/4 in. (6 mm) wide by 3/8 in. (10 mm) long, located opposite the anchor tabs. The collar shall be wrapped over the wrap strip with the overlapping end of the collar cut even with the end of an anchor tab and overlapping the other end of the collar by 1 in. (25 mm). Collar secured to both surfaces of wall at each anchor tab by means of min 1/8 in. (3 mm) diam by 2-1/4 in. (57 mm) long hollow wall anchors in conjunction with 3/16 in. (5 mm) by 3/4 in. (19 mm) diam steel fender washers.

*Bearing the UL Classification Mark

* **Indicates such products shall bear the UL or cUL Certification Mark for jurisdictions employing the UL or cUL Certification (such as Canada), respectively.**